

Linear RF Amplifier

- **Frequency Response: 500-1000MHz**
- **Linear Power: 50 watt**
- **Saturated Power: 90 watts**
- **Gain: 48 dB**

Heatsink
Optional



Description:

Designed for linear application in the 500 to 1000 MHz range. This amplifier that provide high gain, wide dynamic range and an excellent 3rd order interce multi-carrier, pulse, AM & FM modulation.

ELECTRICAL SPECIFICATION @ VDD= +28VDC: Temp.=25°C, 50Ω System

0613

Parameter	Symbol	Min	Typ	Max	Unit
Operating Frequency	BW	500		1000	MHz
Power Output Saturated	P _{sat}		90		Watt
Power Output P-1dB	P _{-1dB}	45	50		Watt
Gain	G	45	47.5		dB
Small Signal Gain Flatness	ΔG		±0.5	±1	dB
Input VSWR	S11		1.45:1	1.55:1	-
Harmonics @ 50 Watts 500-600/650-1000 (MHz)	H		-45	-30 / -38	dBc
Inter-modulation Point 2 Tones, 5W per tone @ 959 & 960MHz	IP ₃		+55		dBm
Spurious Signals	dBc		-70	-60	dBc
Operating Voltage	Vdc	24	28	30	Volt
Operating Current @ 50 Watts	Amps		10	12	Amp
Enable / Disable (shut down pin: gnd=off, open=on)	ms	Typical: 1ms OFF, 10ms ON.			ms

MECHANICAL SPECIFICATION

Parameter	Description	Limits	Units
Dimensions: Module / Module + Heatsink	6.00x2.95x1.04 / 9.75x7.30x6.50	Max	Inch
RF Connectors IN/OUT	SMA	-	-
DC Connectors	Filtered feed-through	-	-
Cooling "Optional"	Heat-sink and fan	-	-
Weight: Module / Module + Heatsink	1 / 8.75	Max	lb

PROTECTIONS

Thermal Shutdown	Bi-metal switch set at 80°C with self reset.	Typ
Input Overdrive	Fold-back overdrive protection to 20 dBm.	Max
Load VSWR	4.0:1 up to 50 Watts	Max
Reverse Polarity Protection	Included	-

ENVIRONMENTAL CHARACTERISTICS

Parameter	Symbol	Min	Typ	Max	Units
Operating Case Temperature	T _c	0°C		+70°C	°C
Storage Temperature	T _{stg}	-30°C		+100°C	°C
Relative humidity non-condensation	RH	95			%

Response Curve

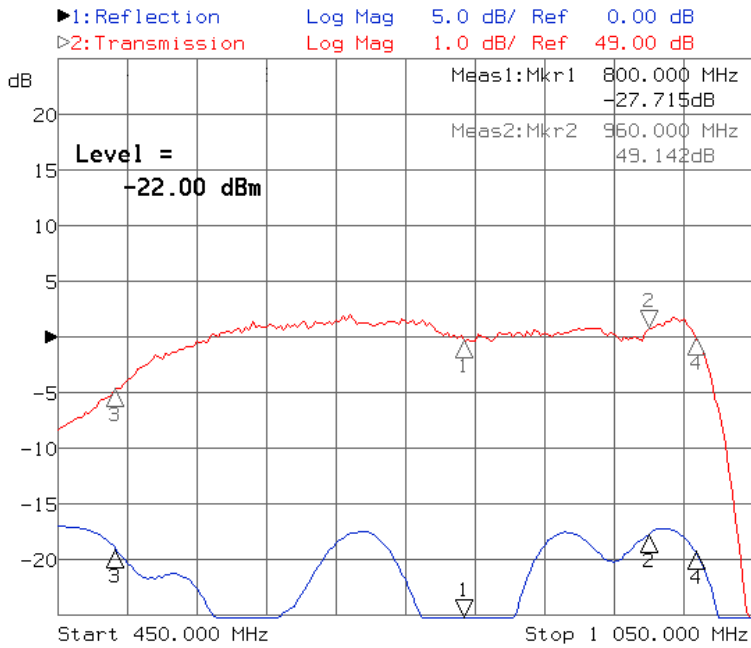

Small Signal Frequency Response Curve

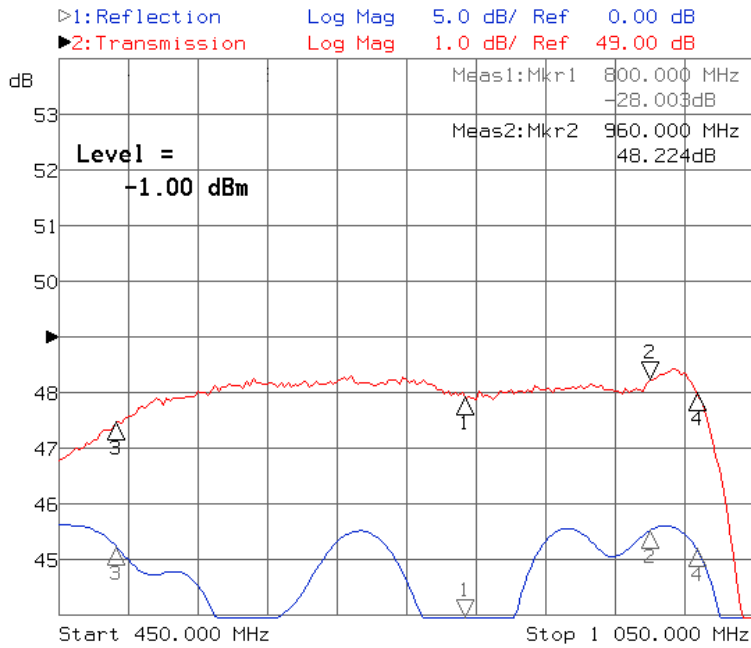

Frequency Response Curve @ 50 Watts Output

Response Curve

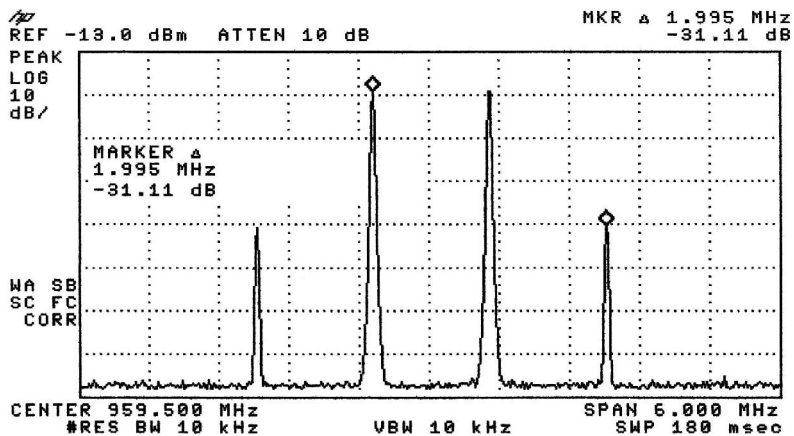

Two Tones 10 Watts Avg. Per Tone @ 959 & 960MHz
 IP3 = +55dBm

Outline Drawing: Module

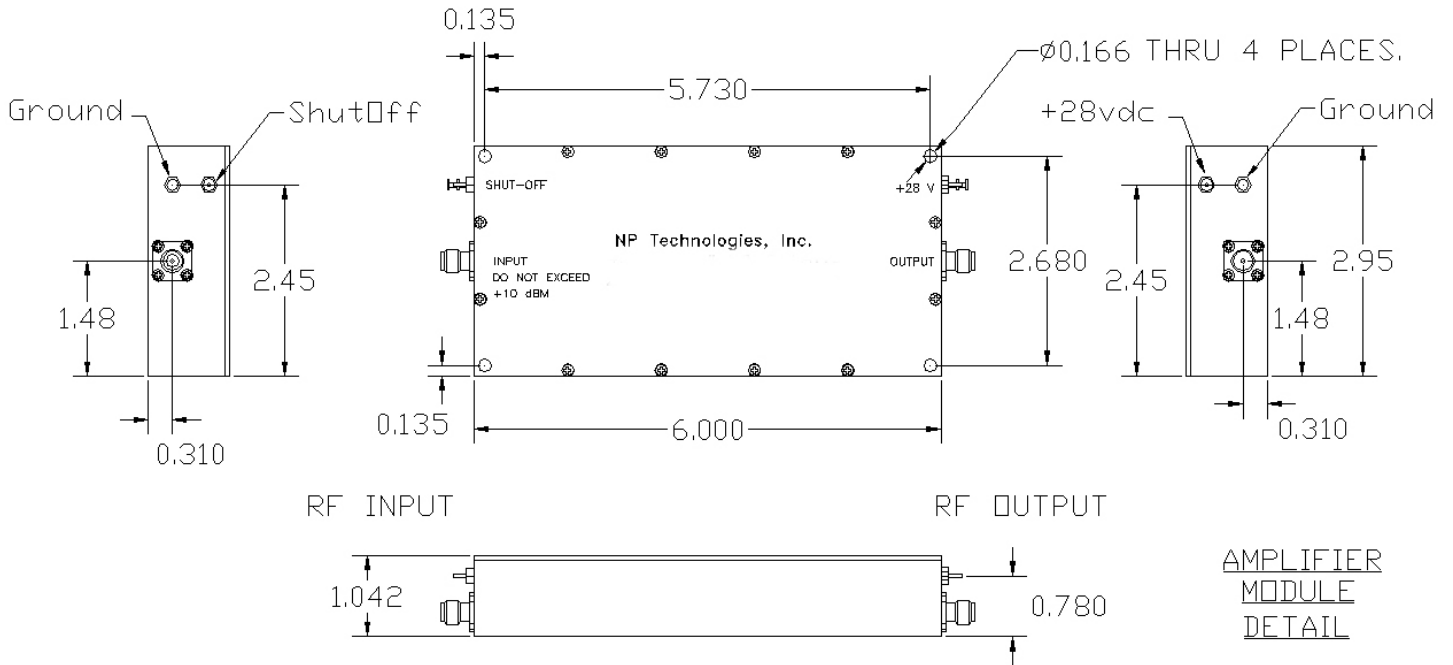

Outline Drawing: Module + Heatsink

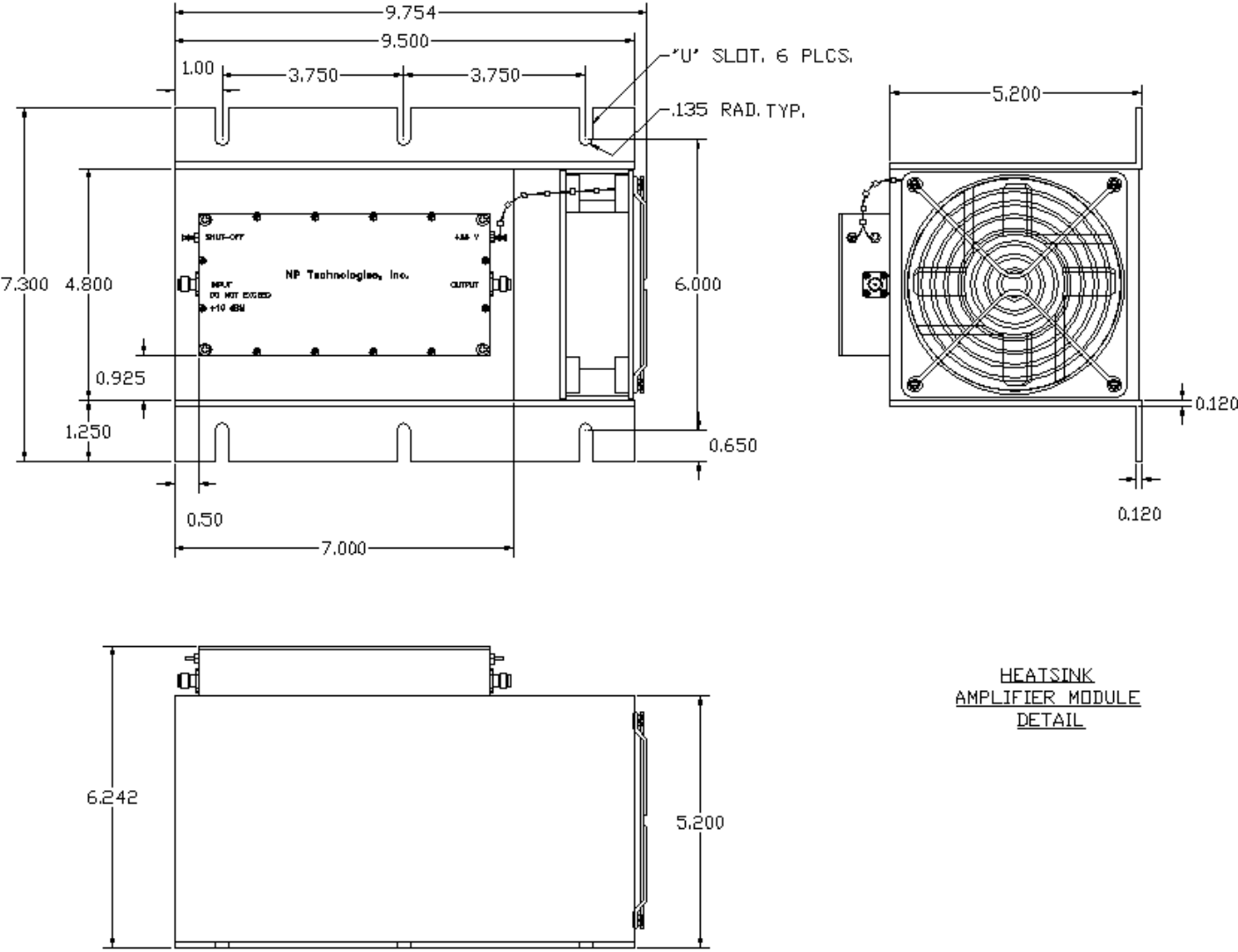

HEATSINK
AMPLIFIER MODULE
DETAIL